

Designing and Specifying Aspheres for Manufacturability

Jay Kumler
Coastal Optical Systems Inc
4480 South Tiffany Drive, West Palm Beach, FL 33407*

ABSTRACT

New technologies for the fabrication of aspheres have increased opportunities for using aspheres in a wider range of optical systems. If manufacturability is considered early in the optical design process, the short and long term costs of the aspheric surface can be greatly reduced without sacrificing performance.

The optical designer must learn how to select optimum materials for aspheres. Using non-staining glasses, higher index glass types, and softer glass types can help reduce production costs. If the optical designer understands what range of aspheric surfaces can be manufactured, they can constrain the aspheric surface during optimization. The steepness of the aspheric departure (the slope of the aspheric departure) often has a larger impact on manufacturing difficulty than the amplitude of the asphere or the steepness of the base radius. Tolerancing can increase the difficulty without measurably improving optical performance. Finally, the asphere can be designed for ease of metrology. Understanding the options that are available for aspheric metrology will allow the engineer to control tooling and fixturing that is required for testing.

Keywords: Aspheric manufacturing, automated fabrication, aspheric metrology

1. INTRODUCTION

Aspheric surfaces can be used in an optical design to correct aperture dependent aberrations (spherical aberration), to correct field dependent aberrations (distortion and field curvature), to reduce weight, to make optical systems more compact, and in some cases to reduce cost.

Commercially available deterministic aspheric polishing machines are making the implementation of aspheric surfaces a practical and commercially viable solution for optical designers. Aspheric finishing machines are available from QED Technologies¹, LOH², and OPTIPRO Systems³. The machines produced by these companies continue to evolve and improve, and new models increase the range of surfaces that can be polished.

Even as new models and machines are introduced, there are certain general design principles that almost certainly will reduce manufacturing difficulty and reduce cost, irrespective of which fabrication facility does the finishing and which automated machines are used. This paper will emphasize sub-aperture lap and sub-aperture MRF techniques, but some of the same guidelines may be applicable to diamond turned optical surfaces.

*jay.kumler@coastalopt.com; phone (561)881-7400, fax (561)881-1947; www.coastalopt.com

2. DESIGN GUIDELINES FOR EASE OF MANUFACTURING

2.1 Shape of the Asphere

Convex versus concave?

Given the choice, should the optical designer try to put the aspheric surface on a concave surface or a convex surface? Many aspheric polishing machines have a minimum radius of curvature for concave surfaces because the polishing wheel or polishing tool has a physical radius that must be less than the radius of curvature of the work piece. Convex surfaces are not constrained by this limitation. A convex parabolic surface with a vertex radius of 15 mm can still be polished with a 35 mm radius polishing wheel. For this reason, if the surfaces being considered for aspherization are shorter than 35 mm vertex radius of curvature, aspherize a convex surface.

Conic Section or Higher Order Asphere?

Rotationally symmetric polynomial aspheric surfaces are described by a polynomial expansion of the deviation from a spherical surface as follows:

$$\text{Surface sag} = Z = cr^2 [1 + \sqrt{1 - (1+k)c^2r^2}]^{-1} + \alpha_1 r^2 + \alpha_2 r^4 + \alpha_3 r^6 + \alpha_4 r^8 + \alpha_5 r^{10} + \alpha_6 r^{12} + \alpha_7 r^{14} + \alpha_8 r^{16}$$

where C is the curvature (the reciprocal of the radius of curvature), r is the radial aperture component in lens units, and k is the unitless conic constant. The higher order aspheric coefficients α_1 through α_8 have units (α_2 units are mm^{-3} , α_3 units are mm^{-5} , etc). Optical design codes allow you to optimize α_1 , but not all computer controlled aspheric manufacturing equipment support the use of the α_1 coefficient in the polynomial expansion. It is safer to use the conic constant and keep the α_1 coefficient equal to 0.

The decision to use a higher order asphere or a conic section impacts performance, manufacturing cost and testing complexity. How much better is performance with higher order aspheres? To investigate this question, we look at a 2-element f/1 transmission sphere made of BK7 (element 1) and fused silica (element 2 with the Fizeau reference surface).

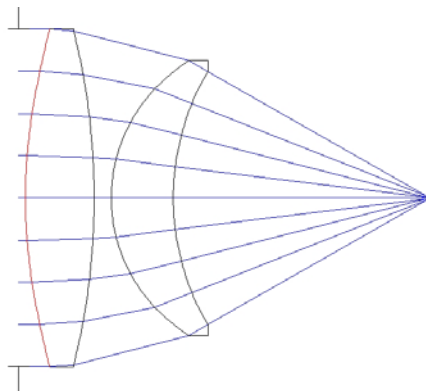

Figure 1 - 2 element f/1 transmission sphere

In this case, a conic on the external convex surface of the BK7 element reduces the transmitted wavefront error to 0.071 waves rms, but the amplitude of the aspheric departure at 120 mm diameter is 2 mm (see Table 1). Going to a 10th order aspheric reduces the single pass transmitted wavefront to 0.0015 waves rms, reduces the aspheric departure over 100 mm diameter by 40% and cuts the aspheric departure over 120 mm diameter from 2 mm to 1.04 mm. The higher order asphere is more manufacturable.

Table 1 - Efficacy of higher order aspheric on f/1 transmission sphere

aspheric order	BK7 and Fused Silica		
	wavefront (waves rms)	aspheric departure at 100 mm diameter (mm)	aspheric departure at 120 mm diameter
spherical	43.600000	0.0000	0.0000
conic	0.071200	0.7655	1.9960
4th order spherical	0.006867	0.8709	2.3407
6th order spherical	0.002886	0.7265	1.8722
8th order spherical	0.000811	0.6305	1.5830
10th order spherical	0.001492	0.4564	1.0367
12th order spherical	0.000970	0.4763	1.0798

How much does it help to add a third spherical element (see figure 2)? Most transmission spheres have three or more elements. Will this eliminate the need for an asphere or make the aspheric element more manufacturable?

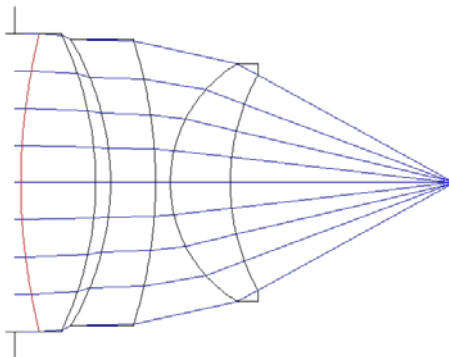

Figure 2 – Three element f/1 transmission sphere example

Table 2 shows that having three elements helps the performance of the spherical and the conic design forms dramatically, but the three element conic design residual wavefront error is 20 times larger than even a 6th order 2 element design, and the two element design is much less sensitive to tilt and decenter errors than the three element design. In this f/1 example, a higher order asphere is more effective at reducing transmitted wavefront error than adding an additional spherical element.

Table 2 - Transmitted wavefront and aspheric departure for 2 and 3 element designs

aspheric order	BK7 and Fused Silica			Three element (BK7/BK7/Fused Silica)		
	wavefront (waves rms)	aspheric departure at 100 mm diameter (mm)	aspheric departure at 120 mm diameter	wavefront (waves rms)	aspheric departure at 100 mm diameter (mm)	aspheric departure at 120 mm diameter
spherical	43.600000	0.0000	0.0000	1.611	0	0
conic	0.071200	0.7655	1.9960	0.0573	0.1971	0.3783
4th order spherical	0.006867	0.8709	2.3407	0.04866	0.514	1.061
6th order spherical	0.002886	0.7265	1.8722	0.02645	0.5151	0.8062
8th order spherical	0.000811	0.6305	1.5830	0.01098	0.4834	0.7575
10th order spherical	0.001492	0.4564	1.0367	0.005673	0.4636	0.7021
12th order spherical	0.000970	0.4763	1.0798	0.005844	0.4674	0.7247

Observations about using higher order aspheres

- When optimizing higher order aspheric coefficients, you must design for a larger aperture than required for the clear aperture of the surface in order to control the polynomial inside the clear aperture and safely outside the margin of the clear aperture. Design for an aperture radius at least one polishing lap footprint larger than the clear aperture.
- When optimizing an optical system that uses a higher order aspheric surface, you must optimize more field points than you can safely use with spherical surfaces. On-axis, full field and 0.7 field points will sufficiently sample a system with all spherical surfaces, but systems with generalized aspheres should have seven to nine field positions in the model.
- Higher order aspheres improve performance in diamond turned optics and molded optics with little or no increase in cost or complexity.
- When designed correctly, higher order aspheres can improve the aspheric fit and reduce the departure and difficulty of the aspheric surface

Testing Aspheric surfaces

Should the optical designer always use higher order aspheric surfaces when designing systems? The strongest arguments to stay with conic sections have to do with the interferometric testing of the aspheric surface. Higher order aspheric surfaces are generalized aspherics that often must be tested with diffractive nulls. Computer generated holograms (CGH's) can test higher order aspheres just as effectively as conics, but separating the desired diffraction order of a CGH null requires some minimal optical correction and/or focal power. Consequently, a very small aspheric departure can be a disadvantage for CGH testing. Computer generated holograms (CGH's) are also very effective at testing off-axis aspheres because CGHs are easily made to compensate differences between the interferometer and asphere axes and such compensation usually aids the task of separating diffraction orders. However, CGH's are expensive and a unique CGH is required for each and every higher order aspheric that will be tested interferometrically.

If an aspheric surface can be constrained to only vary the conic constant, the conic can often be tested at its natural conic foci. A concave parabola, concave hyperbola and concave ellipse (see Figure 3) can be tested without any additional null optics⁴. Even oblate spheroids (concave and convex)⁵, convex hyperbolic mirrors in reflection⁶, and convex hyperbolic mirrors⁷ (see Figure 4,5 and 6) can be tested as null tests without custom null optics.

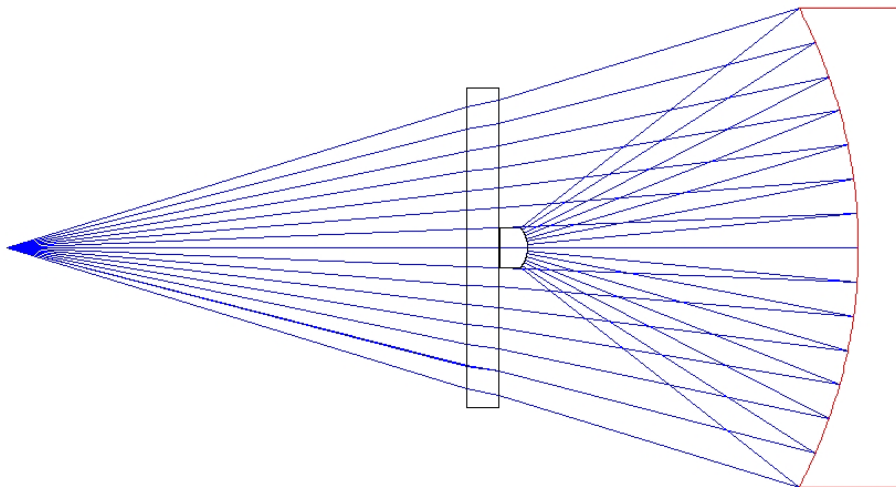

Figure 3 - Null testing concave ellipse at conic foci

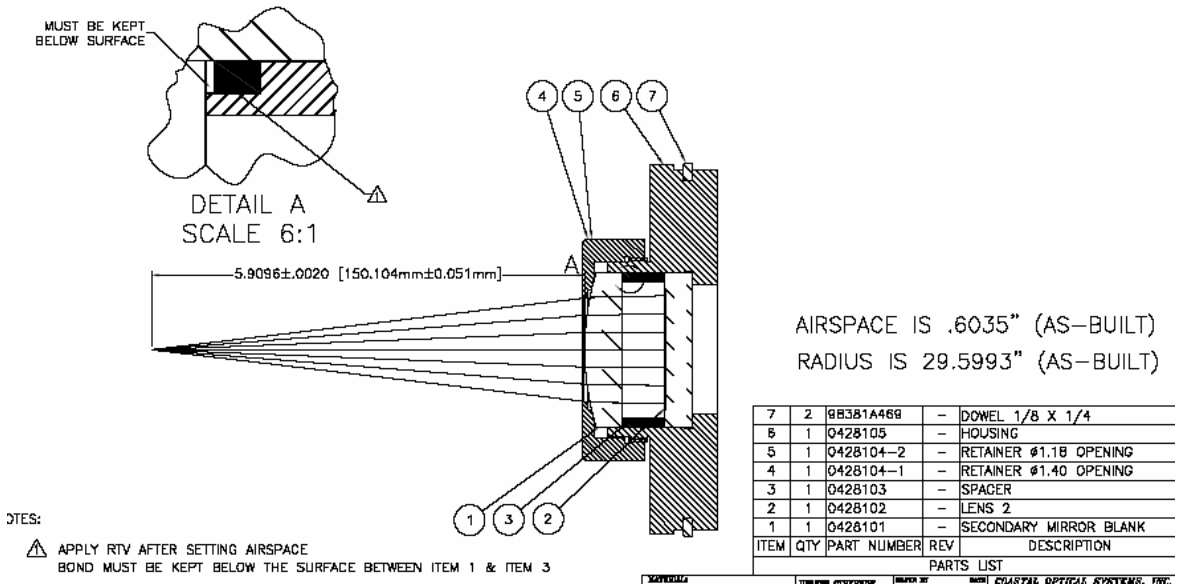

Figure 4 - Testing a convex hyperbolic secondary mirror in transmission

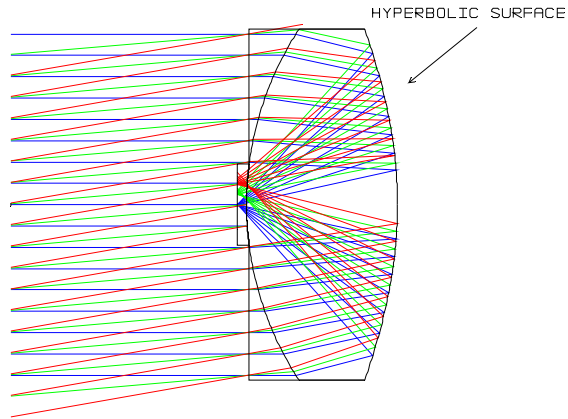

Figure 5 - Hyperbolic collection lens for laser target designator (as used)

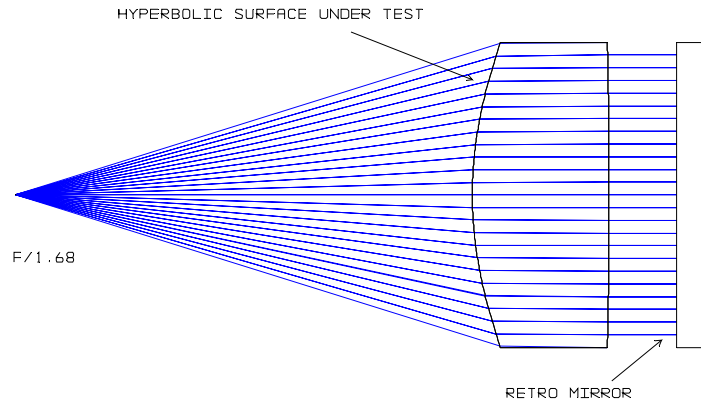

Figure 6 - Testing the same hyperbolic surface in transmission at 632.8 nm as a collimating lens

Steepness of the surface (Aspheric slope)

The greater the slope of the aspheric departure from a best fit sphere, the more difficult the asphere. Figure 7 illustrates that the zone of highest slope of the aspheric departure is often at the outer diameter of the surface. Surfaces with steep slope changes are difficult to test optically, because an interferometer must have the dynamic range to acquire continuous fringes if tested optically, and the polishing footprint must get smaller and smaller to address steep aspheric slopes. If the aspheric departure from best fit sphere is greater than 2 micron aspheric departure per mm of aperture, the aspheric figuring will be slow, it will be difficult to keep the surface smooth, and the interferometric testing will likely be sensitive to decenter errors.

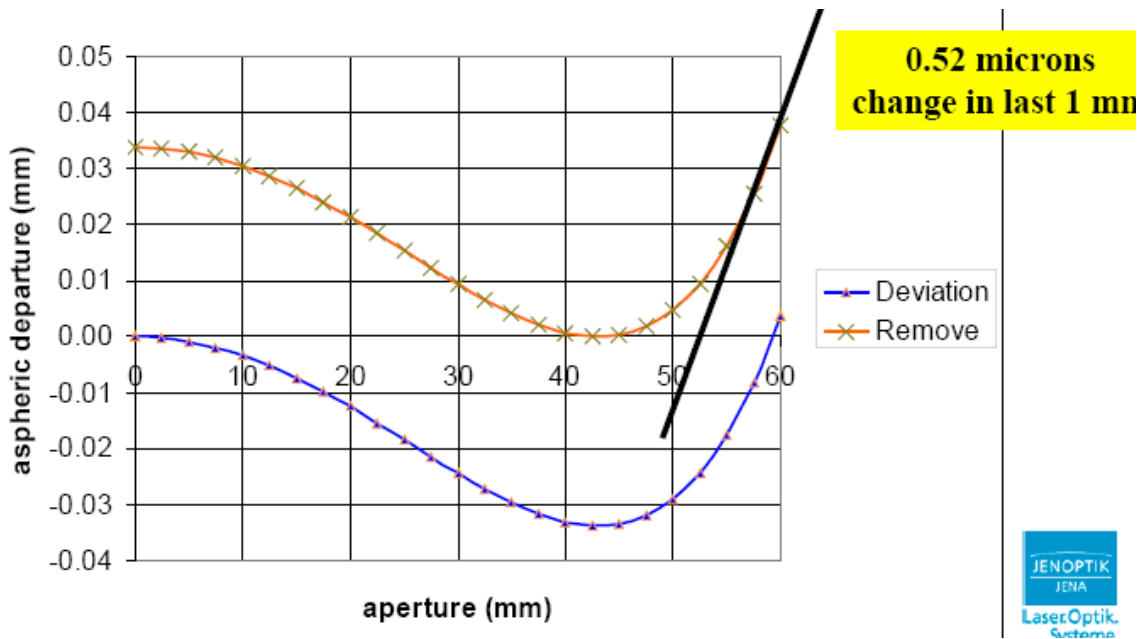

Figure 7 - Slope of the aspheric departure often determines manufacturability

Table 3 - Practical limitations of aspheric figuring by polishing with MRF Technology (at Coastal)

Aspheric amplitude (MRF Polishing only from a polished spherical surface)	50 microns (demonstrated on 90 mm diameter surface)
Aspheric amplitude (aspheric generated and MRF polished)	950 microns departure over 45 mm diameter (see figure 8)
Aspheric slope (MRF only)	2 microns per mm as long as part is < 120 mm diameter
Surface figure accuracy	0.008 wave rms demonstrated on powered aspheres up to 50 mm in diameter
Accuracy of Surface slope	12 microradians peak to peak, demonstrated on space qualified parabolic mirrors 110 mm in diameter over off-axis subaperture ⁸

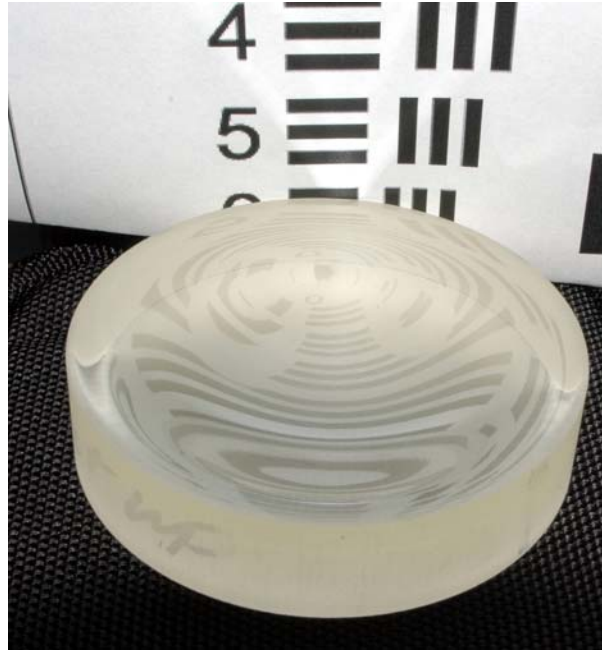

Figure 8 - Aspheric surface with 950 microns departure over 45 mm

Edge thickness - Deterministic aspheric polishing methods require margin on the aspheric surface outside the required clear aperture. As a minimum, a margin of at least one tool footprint should be maintained outside of the lens or mirror clear aperture. If the clear aperture of an aspheric surface is 35 mm and the polishing footprint is 4-5 mm, the lens blank should be at least $35\text{ mm} + 5\text{ mm} + 5\text{ mm} = 45\text{ mm}$ in diameter. If possible, allow 10 mm on the radius as shown in Figure 9. The optical designer should put constraints on the optical design during the optimization process that ensures that lenses maintain enough edge thickness to allow for oversized blanks during fabrication.

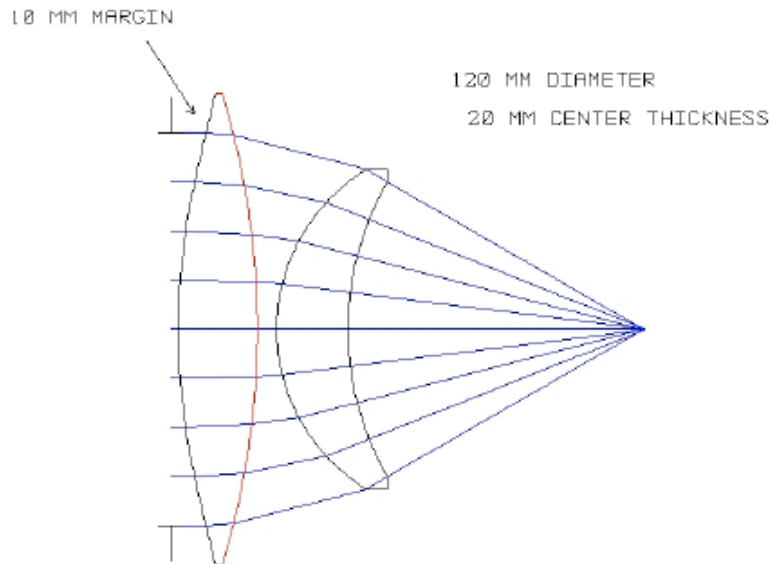

Figure 9 - Allow 10 mm on the radius for aspheric polishing

Size of the asphere

Many aspheric polishing machines have a maximum diameter and a maximum thickness that the machine can process due to mechanical clearances in the machine. The capabilities chart for QED polishers is shown in Figure 10. For the ALG200 and the QED MRF machine, these limits are roughly 240 mm diameter and 90 mm thickness. Profilometers are commonly 120 mm and 200 mm scan lengths. The optical designer should attempt to keep aspheric surfaces within these maximum size limits.

In addition, subaperture lap polishing machines have minimum size limitations. A lap can only effectively correct spatial periods on a surface that are larger than the size of the polishing footprint. If the polisher has a minimum footprint of 4 mm effective diameter, the smallest part that can be corrected is 8 mm in diameter. The smallest conic surface that we have fabricated on the QED was the 12mm diameter convex secondary mirrors for the CALIPSO instrument suite which will launch in September 2005 and will measure vertical distributions of aerosols and clouds in the atmosphere, as well as the optical and physical properties of aerosols and clouds.

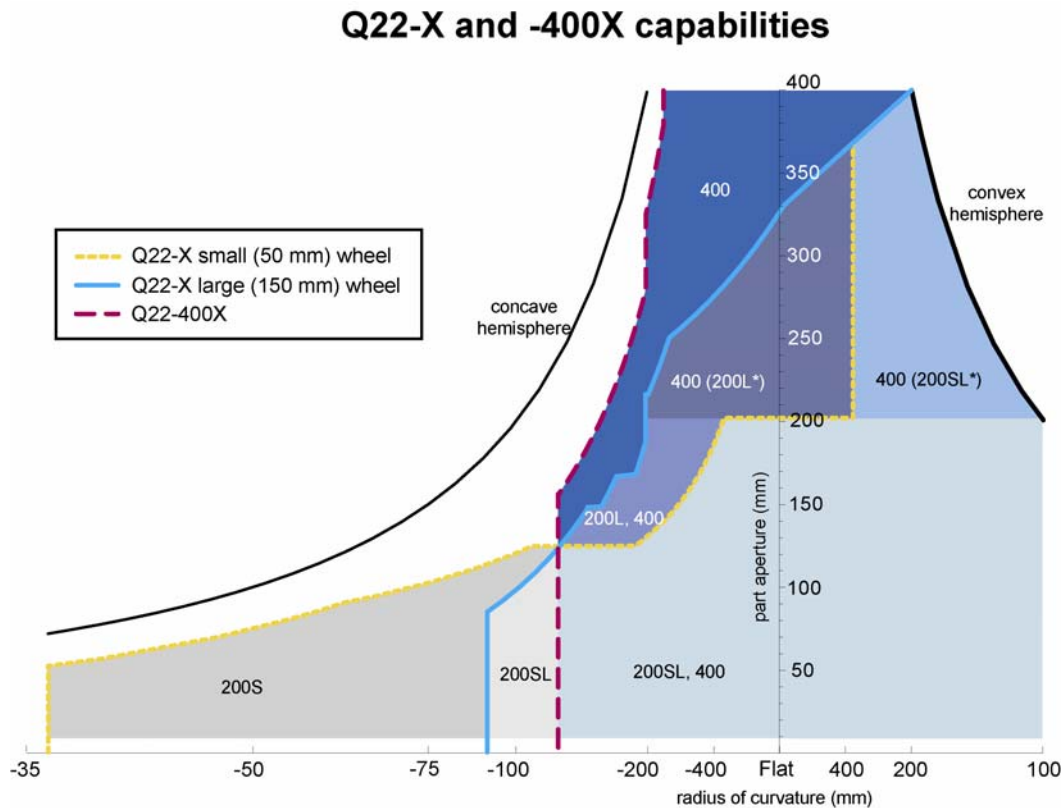

Figure 10 - Size capabilities of QED MRF machines (courtesy of QED)

2.1 Selection of glasses

Stainability - When designing a refractive system, the optical designer should attempt to put the aspheric surface on a non-staining optical glass. The stainability of a glass type can be determined by checking the climactic resistance and staining resistance in optical glass catalogs. Ideally, an optical glass with a staining resistance code of two(2) or less should be used for aspheric elements.

Index of Refraction - The higher the index of refraction, the more bending power and the stronger correction that is achievable. The optical designer will often make the aspheric surface more manufacturable and lower cost if he goes to

a higher index glass of similar dispersion. This is because the vertex radius of curvature can be longer for the same bending, and the aspheric departure can be reduced with the same impact on transmitted wavefront because of the larger change in index of refraction at the air to glass interface.

3. TOLERANCING FOR EASE OF MANUFACTURING

When tolerancing the optical system, keep the surface figure accuracy requirements on the aspheric surfaces as loose as possible. If polished glass aspheres are 10 times more expensive to fabricate in production than spherical surfaces, an optical designer can save production costs if he balances surface figure error and radius of curvature tolerances so that the surface figure accuracy requirements on aspheres are two or three times looser than the spherical surfaces. High performance visible projection systems can have 0.5-1.0 wave surface figure accuracy on the 20-30 spherical surfaces and 3 to 4 wave surface figure accuracy on the single aspheric surface.

If the surface figure accuracy of the asphere is 1 micron or looser, contact profilometry can be used to qualify the surface. This eliminates the need for computer generated holograms (CGH's) or null lenses. Significant savings can be realized when 1 micron figure accuracies can be balanced in the performance error budget.

4. CONCLUSION

New technologies in optical fabrication have increased the practicality of implementing aspheric surfaces in precision optical surfaces. Even with improved fabrication methods, the optical designer should take responsibility for designing the optical system with aspheric surfaces that are of minimum cost, and maximum manufacturability.

ACKNOWLEDGMENTS

The author thanks Marc Neer of Coastal Optical Systems for his input and his work in advancing precision aspheric fabrication, Dr. Steve Arnold for discussions on CGH testing for this paper, Dr. Brian Caldwell for his technical input on designing with aspheres, and QED Technologies for technical support of fabrication efforts.

REFERENCES

1. QED Technologies, 1040 University Avenue, Rochester NY 13607
2. Loh Optikmaschinen GmbH, Wilhelm-Loh-Strabe 2-4, Postfach 20 69, D-35573 Wetzlar
3. OptiPro Systems, 6368 Dean Parkway, Ontario, NY 14519-8939
4. Daniel Malacara, *Optical System Testing*, Wiley-Interscience; 2nd edition (January 1992)
5. "Null tests of Oblate spheroids, John M. Rodgers and Robert E. Parks, Applied Optics, Vol 23, No. 8 (15 April 1984)
6. "Null test for hyperbolic convex mirrors", Donald Bruns, Applied Optics, Vol. 22, No. 1 (1 January 1983).
7. "Self-null corrector test for telescope hyperbolic secondaries" Aden B. Meinel and Marjorie P. Meinel, Applied Optics, Vol. 22, No. 4 (15 February 1983)
8. http://smc.cnes.fr/CALIPSO/GP_mission.htm